

## 5720F7 NEW MILL TIER FOUNTAIN ASSEMBLY INSTRUCTIONS

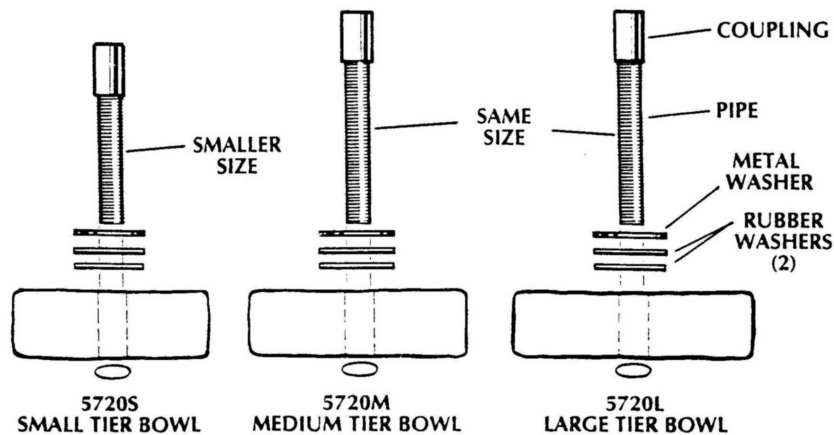
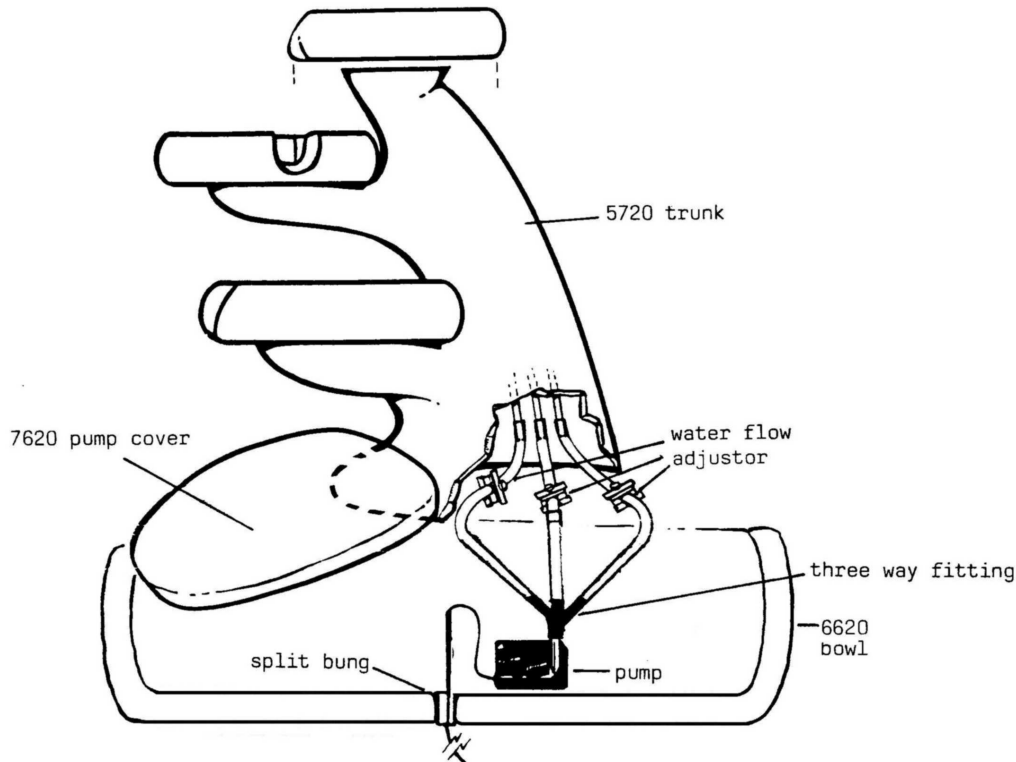

For details of the split bung and electrical installation, see page 18 of the Fact Book  
For added stability and balance, use the wedges and mastic strip supplied

### **Important Winter Care**

**Do not allow water to collect and freeze in fountain bowl(s) or shell. Do not allow fountain to sit in a pool of ice. Disassemble entire fountain and pump and store indoors during the winter season.**

If you cannot store your fountain indoors during the winter season, you must at least protect it from ice collection or exposure. "How" to protect your fountain during the winter: First remove the statue and pump, storing them inside if possible. Next locate the drain plug on the underside of the bowl(s) or shell. Remove the drain plug to drain any water 'trapped' between the walls of the bowl(s) or shell. Then fill the bowl(s) or shell with an absorbent material such as burlap, blanket, etc. Finally cover the entire fountain with a Henri Fountain cover. Should condensation droplets form on the inside of the cover, they will be absorbed by the material. By following these simple and sensible precautions during the winter season, you will protect your fountain for years of enjoyment.